

## DURAG D-FW 440 L Filter leakage monitor certified to EN 15859

Continuous surveillance of industrial filtration systems such as baghouses, cyclones, and exhaust ducts – early detection of filter failures

- **Cost-effective and highly reliable in situ filter monitor:**  
Designed for real-time detection of filter leaks.
- **Certified to EN 15267-1/-2 and EN 15859 and US EPA capable:** Engineered for low maintenance, measures solid particles in gas flows with precision.
- **Triboelectric principle:** Robust and reliable technology, reducing filter maintenance intervals, process down-time, and filter costs.



[Digital Version](#)

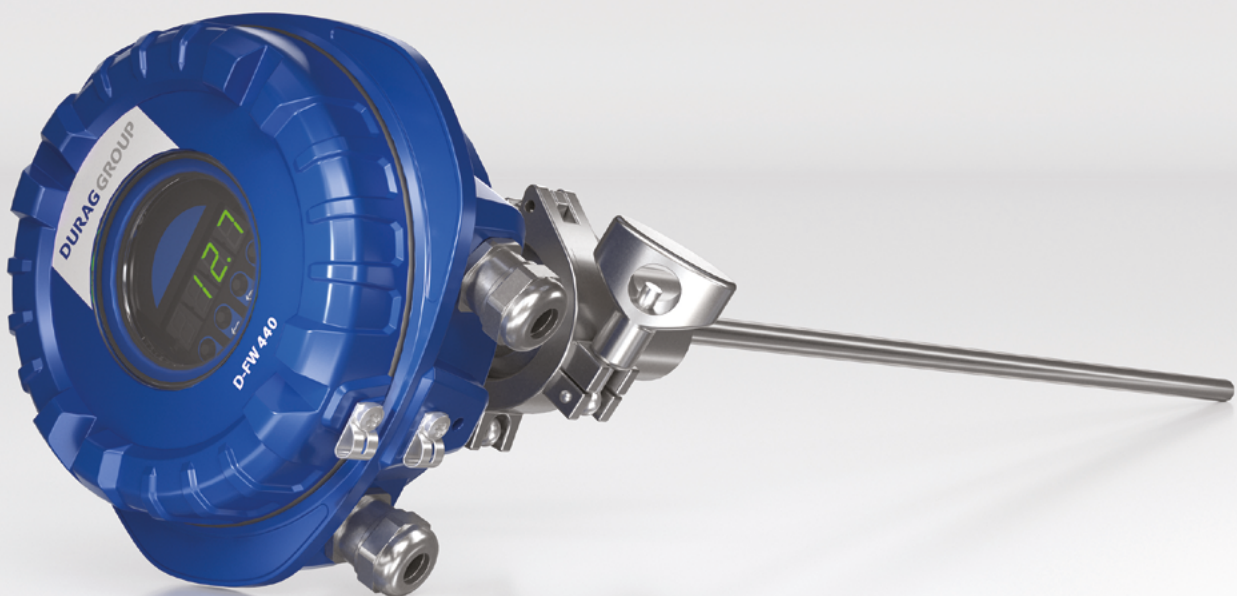

## ONE COMPANY | COMPREHENSIVE SOLUTIONS

### Local support, global reach

Benefit from local commissioning and services through our extensive network of partners and corporate organizations, ensuring prompt assistance and expertise wherever you are.

### One company, comprehensive solutions

DURAG GROUP offers a comprehensive solution for your plant, from combustion optimization and safety to environmental compliance and atmospheric impact monitoring.

## FEATURES AND BENEFITS

- Cost-effective filter leakage monitoring**  
 Ideal for basic process control, trend analysis, and filter performance monitoring, in applications not requiring direct concentration output
- Regulatory compliance made easy**  
 Filter leakage monitoring in accordance with EN 15267-1/-2, EN 15859 and other international standards
- Proven triboelectric technology**  
 Reliable particle detection based on charge interaction – trusted in demanding industrial environments worldwide
- Quick + easy installation**  
 Compact and easy to mount – ready to measure in no time, perfect for upgrades or tight spaces
- Seamless system integration**  
 Standard 4 to 20 mA output signal and 2 independent alarm relays (normally open/closed) – ideal for immediate alarm notifications or switching signals in case of leakages or filter failure
- Direct, in-situ measurement**  
 No sampling or extraction – direct measurement within the gas duct for real-time accuracy
- Maintenance-free operation**  
 No moving parts, no consumables – reducing downtime and lowering long-term operating costs
- Supports predictive maintenance**  
 Detects changes in filter cleaning pulse magnitude or emission levels – enabling proactive maintenance and reducing unplanned downtime
- Improved environmental + operational efficiency**  
 Helps meet dust emission limits, avoid fines, and minimize product losses due to filter failures
- Enhanced safety**  
 Continuous monitoring reduces the risk of hazardous exposure and dust explosions
- Versatile applications**  
 Suitable for a wide range of industries including cement, steel, pharmaceuticals, power generation, and more

## TECHNICAL DATA

<b>Measured parameter</b>	Solid particles in gas flow
<b>Measuring principle</b>	Triboelectric, in situ measurement, single-sided installation
<b>Measuring range</b>	<ul style="list-style-type: none"> <li>Detection limit 0.01 mg/m<sup>3</sup></li> <li>Certification range: 0 ... 7.5 mg/m<sup>3</sup>;</li> <li>Additional ranges: 0 ... 15 mg/m<sup>3</sup>; 0 ... 100 mg/m<sup>3</sup></li> <li>Max. range up to several g/m<sup>3</sup> depending on operating conditions and dust material</li> </ul>
<b>Protection rating</b>	IP66
<b>Power supply</b>	24 V= (±10%) 100 ... 240 V~ ±10%, 50/60 Hz
<b>Power consumption</b>	Max. 10 W DC/AC
<b>Output signals</b>	<ul style="list-style-type: none"> <li>2x independent SPDT output signal relays, max. 30 V=/5 A or 240 V~/5 A, cos = 1, certified to EN 15859</li> <li>Isolated active 4 ... 20 mA output loop, max. loop resistance 250 Ω</li> </ul>
<b>Communication interface</b>	2x RS-485 (serial), 1x USB
<b>Communication protocol</b>	Modbus RTU (with RS-485), compliant with VDI 4201
<b>Ambient conditions</b>	<ul style="list-style-type: none"> <li>Temperature: -20 ... 50 °C (-4 ... 122 °F)</li> <li>Humidity: Max. 95% relative humidity (non-condensing)</li> </ul>

<b>Process conditions</b>	<ul style="list-style-type: none"> <li>Temperature: Max. 300 °C (572 °F), optionally up to 700 °C (1,292 °F)</li> <li>Pressure:                             <ul style="list-style-type: none"> <li>Max. 600 kPa (87 psi) in temperatures up to 300 °C (572 °F)</li> <li>Max. 300 kPa (43 psi) in temperatures 300 °C (572 °F) ... 700 °C (1,292 °F) when high-temperature process connection is used</li> </ul> </li> <li>Flow velocity: Min. 3 m/s (9.84 ft/s), max. tested 40 m/s (131.23 ft/s)</li> </ul>
<b>Operation + configuration</b>	Optional: D-ESI FW software
<b>Material</b>	<ul style="list-style-type: none"> <li>Housing: Aluminium, painted</li> <li>Probe: Stainless steel (316L)</li> <li>Insulation: Polyphenylene sulfide (Ryton R-4)</li> </ul>
<b>Probe dimensions</b>	Standard length: 500 mm (19.69"); Other lengths on request – up to 1,750 mm (68.90") in 250 (9.8") or 500 mm (19.69") increments
<b>Weight</b>	1.5 kg (3.3 lb) without probe

D-FW 440 L | DIMENSIONS, SIDE VIEW

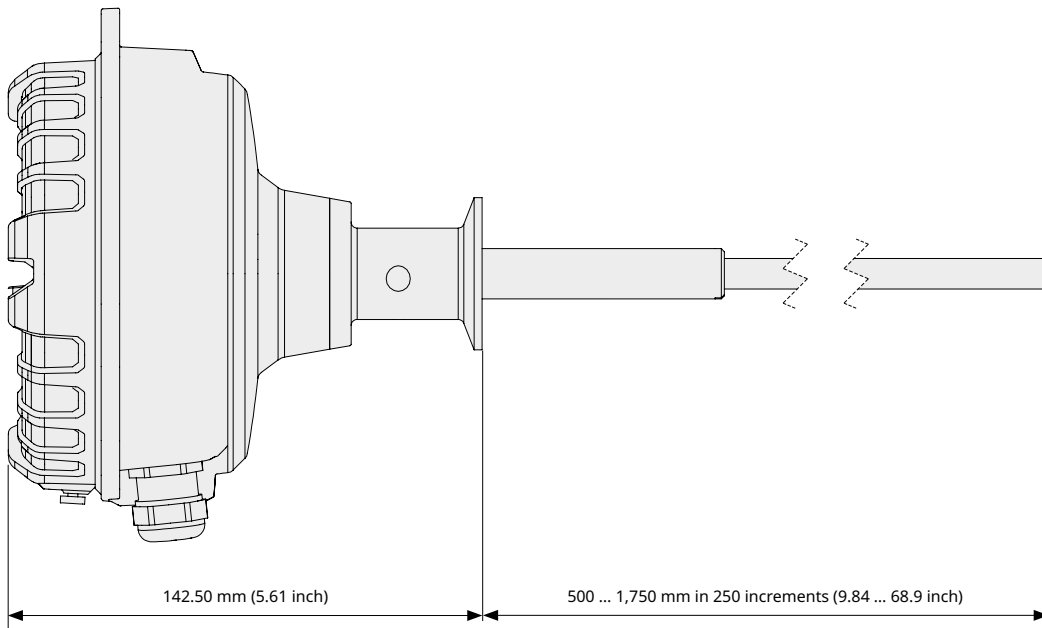

D-FW 440 L | DIMENSIONS, FRONT VIEW

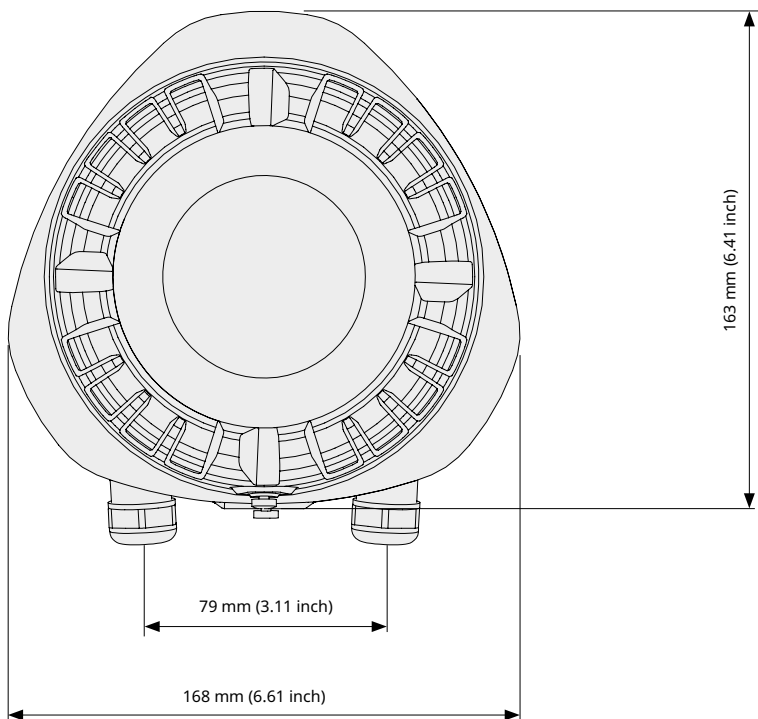

**DURAG GROUP**

Kollaustr. 105  
22453 Hamburg, Germany  
Phone +49 40 554218-0  
info@durag.com

**DURAG.COM**

Follow us on **LinkedIn**

---